



**MEEK MIRRORS, LLC**  
 PO Box 11200  
 Fort Smith, Arkansas 72917-1200  
 800-643-2533 Fax 479-646-6231  
**www.meekmirrors.com**

**Architectural  
 Specification**

ONE PIECE STAINLESS STEEL SECURITY MIRROR	DATE January 2018	MODEL M5500 M5500P M5600 M5600P	SHEET NO. 7-01
--	----------------------	---------------------------------------	-------------------

**MODEL M5500 AND M5600  
 MODEL M5500P AND M5600P**

**ONE PIECE STAINLESS STEEL SECURITY MIRROR  
 SAME AS ABOVE WITH STEEL BACKPLATE INCLUDED**

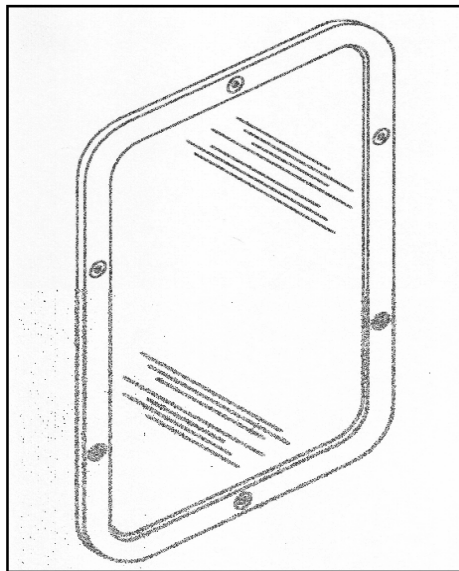

**MATERIALS:** Constructed of 20 gauge stainless steel with a No.8 architectural mirror finish.

**FEATURES:** Model numbers M5500 and M5500P measure 11-1/4" x 17-1/4" and model numbers M5600 and M5600P measure 11-1/4" x 9-1/2". This mirror is theft resistant and unbreakable. It is ideal for penal and mental institutions, road side stops, parks or any other restroom that is subject to high vandalism.

**INSTALLATION:** This mirror is mounted with No.1/4-20 button head socket cap safety screws which are included. For installation on masonry or concrete walls, a 3/16" steel plate is recommended. The steel plate is included with model numbers M5500P and M5600P.

**GUARANTEE:** Meek Mirrors gives a one year guarantee on all of their products against defects in workmanship and material.

**SPECIFICATION:** Product shall be Model M5500, M5500P, M5600, or M5600P as distributed by Meek Mirrors - Fort Smith, Arkansas. Above data is applicable to productions as of the date of this technical data sheet. The manufacturer reserves the right to make changes in design without formal notice.