

	6201 S ZERO ST FORT SMITH, AR	CHANNEL FRAMED MIRROR M1500 & M2500 SERIES	
	800-643-2533 MEEKMIRRORS.COM	ARCHITECTURAL SPECS	JULY 2017

M1500 / M1510 STAINLESS STEEL CHANNEL FRAMED MIRROR

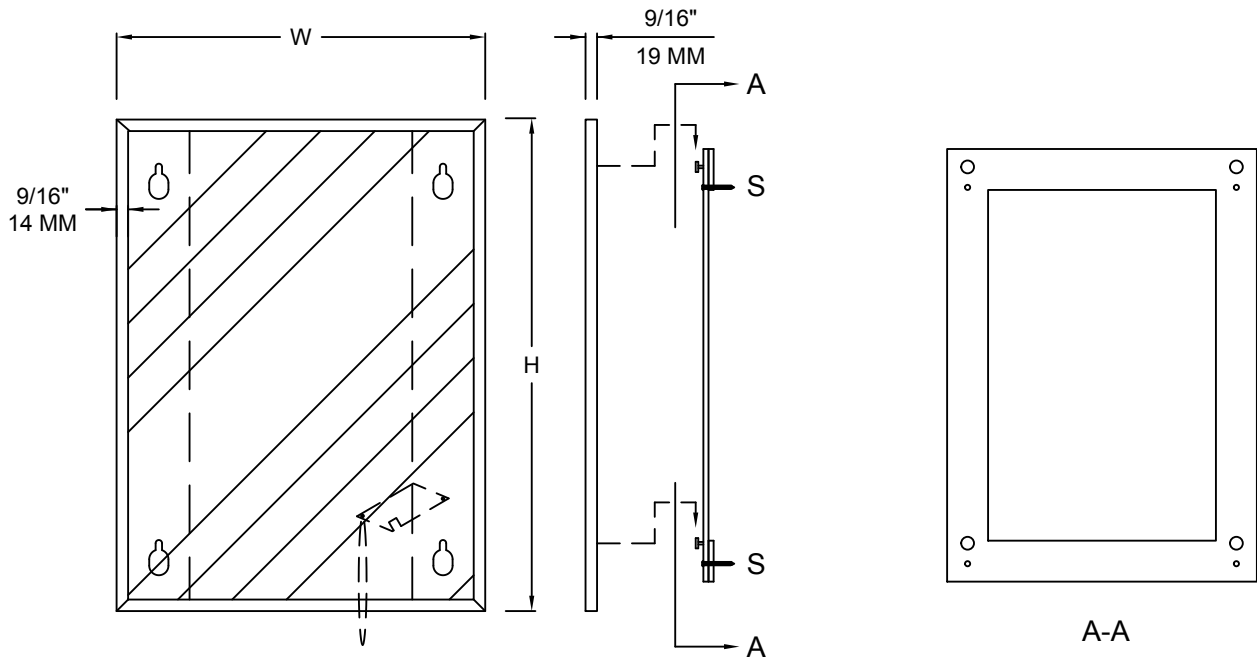

MIRROR: NO. 1 QUALITY 1/4" (6MM) THICK FLOAT GLASS MIRROR, ELECTROLYTIC COPPER BACK, GUARANTEED FOR 15 YEARS AGAINST SILVER SPOILAGE. OTHER GLAZES AVAILABLE.

MIRROR PROTECTION: PROTECTED BY SHOCK-ABSORBING EXPANDED POLYSTYRENE SHEETS.

WALL PLATE: 22 GAUGE (.76MM) QUALITY CORROSION-RESISTANT GALVANIZED STEEL STRIPS WITH PUNCHED HOLES IN SUPPORT AREAS.

BACK PLATE: 22 GAUGE (.76MM) LOCK FORMING QUALITY CORROSION-RESISTANT GALVANIZED STEEL STRIPS WITH PRECISION PUNCHED HOLES FOR QUICK, EASY INSTALLATION.

FRAME: CHANNEL FRAME, 9/16"X9/16"X9/16" (14MM X 14MM X 14MM), IS CONSTRUCTED FROM A TYPE 430 (OR 304 FOR M2500), 22 GAUGE STAINLESS STEEL WITH MITERED CORNERS IN SATIN BRUSHED FINISH OR A BRIGHT POLISHED FINISH (OPTIONAL).

GUARANTEE: MEEK MIRRORS GIVES A ONE YEAR GUARANTEE ON ALL OF THEIR PRODUCTS AGAINST DEFECTS IN WORKMANSHIP AND MATERIAL. IMPROPER INSTALLATION VOIDS WARRANTY. MIRROR GLASS IS GUARANTEED 15 YEARS AGAINST SILVER SPOILAGE.

SPECIFICATION: PRODUCT SHALL BE MODEL M1500 OR M2500 AS MANUFACTURED BY MEEK MIRRORS, FORT SMITH, ARKANSAS. ABOVE SPECIFICATION IS APPLICABLE TO PRODUCTIONS AS OF THE DATE OF THIS TECHNICAL SPECIFICATION SHEET. THE MANUFACTURER RESERVES THE RIGHT TO MAKE CHANGES IN DESIGN WITHOUT FORMAL NOTICE.

PRODUCT MADE IN THE USA.

VETERAN OWNED SMALL BUSINESS